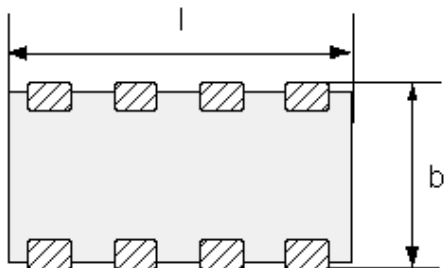

**Preliminary data sheet**

(parameters may be changed if necessary)

**Designation System:**

- CA = **C**hip **A**rray  
 06 = Dimensions of the device **06**x12 (Length x width in 1/100 inch)  
 P = Design (**P**arallel internal structure)  
 4 = Number of elements  
 V = **V**aristor  
 150 = Typical varistor voltage  
 T = **T**hree layer termination (Ag/Ni/Sn)  
 HS = Designed for **H**igh **S**peed applications  
 G = Taped version (blister tape, 7" reel, 3000 pieces/reel)

**Figure:**

$$\begin{aligned}
 l &= 3,2 \pm 0,2 \\
 b &= 1,6 \pm 0,15 \\
 s &= 0,9 \text{ max.} \\
 d &= 0,4 \pm 0,15 \\
 e &= 0,76 \pm 0,15
 \end{aligned}$$

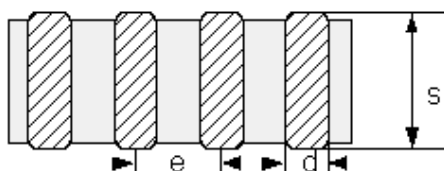

Coplanarity &lt; 0.1

(All dimensions in mm)

As far as patents or other rights of third parties are concerned, liability is only assumed for components per se, not for applications, processes and circuits implemented within components or assemblies. The information describes the type of component and shall not be considered as assured characteristics. Terms of delivery and rights to change design reserved.

ISSUE DATE	21.07.03	ISSUE	a	PUBLISHER	KB VS PE	PAGE	1/5
------------	----------	-------	---	-----------	----------	------	-----



**Metal Oxide Varistor**

**CA06P4V150THSG**

**SMD Multilayer Varistor Array with Ag/Ni/Sn Termination**

**B72724A8151V062**

**Preliminary data sheet**

(parameters may be changed if necessary)

## **Electrical Data**

Max. operating voltage

RMS voltage

**$V_{\text{eff}} = 14 \text{ V}$**

DC voltage

**$V_{\text{DC}} = 16 \text{ V}$**

Varistor voltage (@ 1 mA, typ.)

**$V_{\text{v}} = 150 \text{ V}$**

Max. varistor voltage (@ 1mA)

**$V_{\text{vmax}} = 175 \text{ V}$**

Max. leakage current (@ 5 V; 25°C, unsoldered)

**$I_{\text{smax}} = 3 \mu\text{A}$**

Max. clamping voltage

**$V_{\text{C}} = 350 \text{ V}$**

Capacitance (@ 1MHz, 1 V; 25°C, typ.)

**$C = 3 \text{ pF}$**

Operating temperature

**-40 ... +85 °C**

Storage temperature (mounted parts)

**-40 ... +125 °C**

Termination material

**Ag/Ni/Sn**

## **Application Note**

The described component is designed to meet ESD level 4 requirements acc. IEC61000-4-2 (8kV contact discharge 150pF, 330 Ω).

Due to the ultra low capacitance value in combination with low insertion losses up to 1 GHz this component is well suited for the ESD protection of high speed datalines (USB ports, Ethernet ports etc.) in e.g. note books, digital cameras, PDAs, printers....

ISSUE DATE	21.07.03	ISSUE	a	PUBLISHER	KB VS PE	PAGE	2/5
------------	----------	-------	---	-----------	----------	------	-----

**Preliminary data sheet**

(parameters may be changed if necessary)

**Recommended Geometry of Solder Pads**

A = 0,5 mm  
 B = 0,7 mm  
 C = 1,2 mm  
 E = 0,76 mm

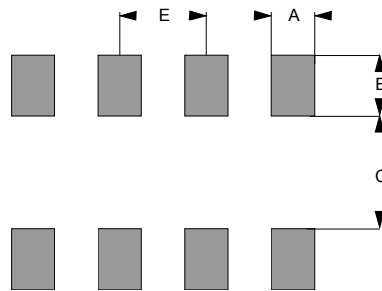
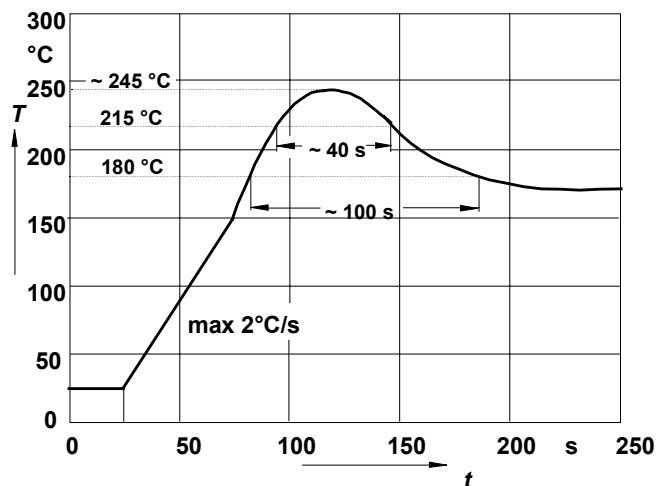
**Recommended Soldering Temperature Profiles**

The components should be soldered within 12 months after delivery from EPCOS. The parts are to be left in the original packing in order to avoid any soldering problems caused by oxidized terminals.

Storage temperature: -25 to 45°C.

Relative humidity: <75% annual average, <95% on max. 30 days in a year.

The usage of mild, non activated fluxes for soldering is recommended, as well as proper cleaning of the PCB.

Preliminary data sheet

(parameters may be changed if necessary)

## Taping According to IEC 60286-3

Dimensions and tolerances

Tape material: plastic embossed

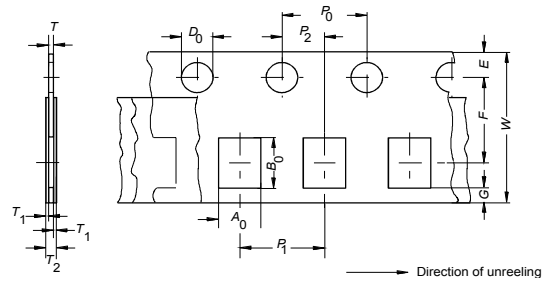

Definition	Symbol	Dim.	Tolerance
Compartment width	$A_0$	1.9	$\pm 0.2$
Compartment length	$B_0$	3.5	$\pm 0.2$
Compartment height	$K_0$	1.3	max.
Sprocket hole diameter	$D_0$	1.5	$+0.1 / -0$
Compartment hole diameter	$D_1$	1.0	min.
Sprocket hole pitch	$P_0$	4.0	$\pm 0.1$ <sup>1)</sup>
Distance center hole to center compartment	$P_2$	2.0	$\pm 0.05$
Pitch of the component compartments	$P_1$	4.0	$\pm 0.1$
Tape width	$W$	8.0	$\pm 0.3$
Distance edge to center of hole	$E$	1.75	$\pm 0.1$
Distance center hole to center compartment	$F$	3.5	$\pm 0.05$
Overall thickness	$T_2$	2.5	max.

<sup>1)</sup>  $\leq \pm 0.2$  mm over any 10 pitches

Tape end (trailer)

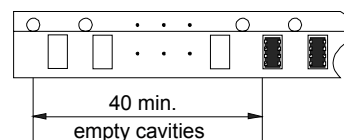

Leader

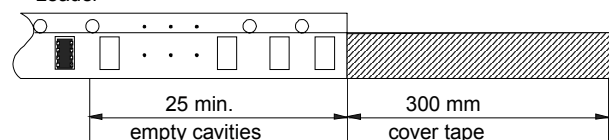

**Preliminary data sheet**

(parameters may be changed if necessary)

**Package**

Dimensions approx. 220 x 200 mm.

6 bags in cardboard box; dimensions approx. 250 x 220 x 130 mm.

Package: 8 mm tape

Reel material: plastic

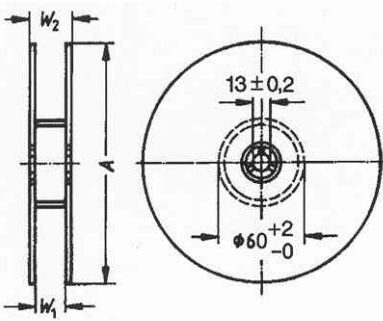

Definition	Symbol	Dim.	Tol.
Reel diameter	A	180	-2
Reel width (inside)	$W_1$	8.4	+1.5 /-0
Reel width (outside)	$W_2$	14.4	max.

© EPCOS AG 2002. Reproduction, publication and dissemination of this data sheet, enclosures hereto and the information contained therein without EPCOS' prior express consent is prohibited.

Purchase orders are subject to the General Conditions for the Supply of Products and Services of the Electrical and Electronics Industry recommended by the ZVEI (German Electrical and Electronic Manufacturers' Association), unless otherwise agreed.

ISSUE DATE	21.07.03	ISSUE	a	PUBLISHER	KB VS PE	PAGE	5/5
------------	----------	-------	---	-----------	----------	------	-----